

Date : 12/09/2021
 Événement : CF
 Pilote : Sam Bulle

Moteur : MPR
 Embayage : Tourex
 Échappement : Big tornado
 Différentiel : SCS 2
 Carrosserie : Alfa

Piste : Grenoble
 Aspect : Bon
 Grip : Très bon
 Conditions : Sèche
 T° Air : 25°
 T° Piste :
 Pneus AV: Pmt soft
 Pneus AR: Pmt soft

TRAIN AR

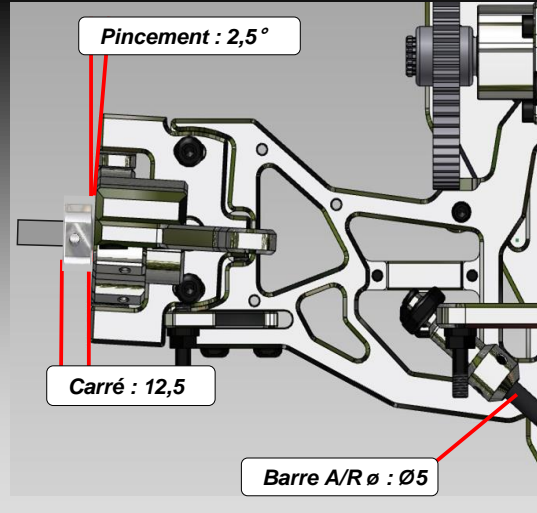
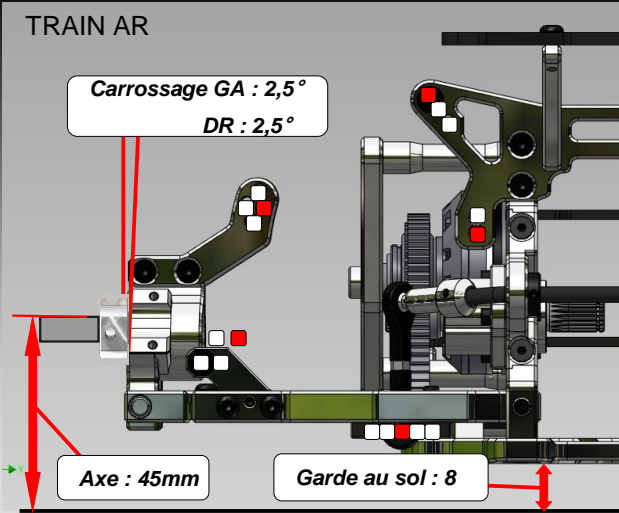

Arrière

Genius dynamique

Ressort: Orange

Huile : 5000

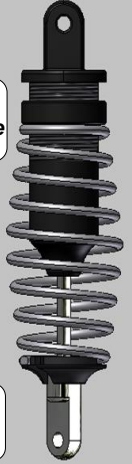

TRAIN AV

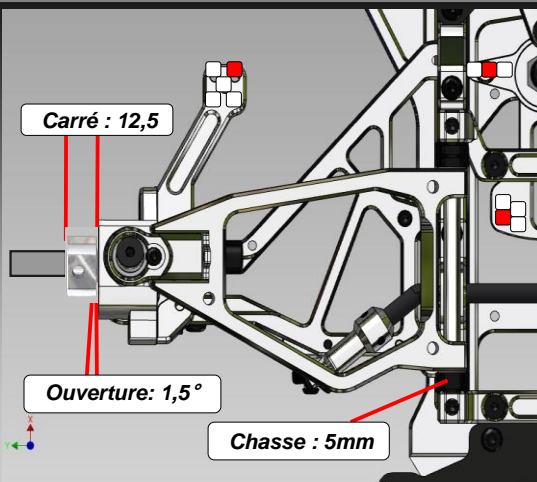
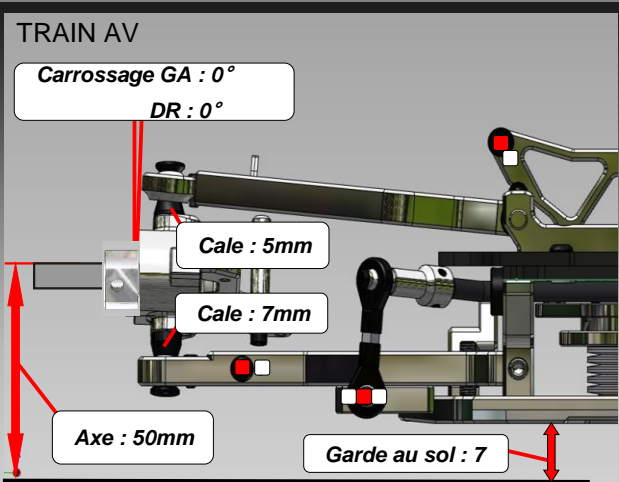

Avant

Genius dynamique

Ressort: Blanc

Huile : 6500

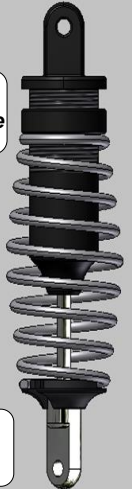

TRANSMISSION

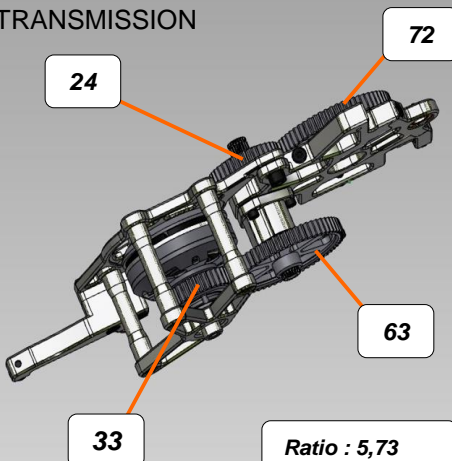

RATIOS

| | | | | |
|---|----|----|----|------|
| 7 | 24 | 63 | 31 | 6,10 |
| 2 | | | | |
| 7 | 24 | 63 | 32 | 5,91 |
| 2 | | | | |
| 7 | 25 | 63 | 31 | 5,85 |
| 2 | | | | |
| 7 | 24 | 63 | 33 | 5,73 |
| 2 | | | | |
| 7 | 25 | 63 | 32 | 5,67 |
| 2 | | | | |
| 7 | 24 | 63 | 34 | 5,56 |
| 2 | | | | |
| 7 | 25 | 63 | 33 | 5,50 |
| 2 | | | | |

Ressorts AR

JAUNE - ø2.5 / 8

GRIS - ø2.6 / 8

VERT F - ø2.65 / 8

NOIR - ø2.7 / 9

BLEU - ø2.7 / 8.5

VERT - ø2.7 / 8

+ ORANGE - ø2.75 / 8

Ressorts AV

OR - ø2.8 / 8

ROUGE - ø2.9 / 8

BLANC - ø3.0 / 8

+ ROSE - ø3.2 / 8

NOTES

Pièce proto:
 Nouveau point
 d'encrage au niveau
 du support
 d'amortisseur
 arrière inférieur

